

PAPI-LED | LED Precision Approach Path Indicator (PAPI) - Airsafe



COMPLIANCE:

- ICAO Annex. 14, Vol.I
- FAA AC 150/5345-28
- EASA: CS-ADR-DSN.
- STANAG 3316
- AENA PPT-020_04-12



BOARDING TIME

BOARDING PASS

NAME OF PASSANGER

FROM:

TO:

DATE FLIGHT
 GAES2020

GATE SEAT
23 21B

GATE CLOSSES 30 MINUTES BEFORE DEPARTURE

BOARDING PASS

Uses

LED Precision approach path indicator for airports CAT I, II & III, according to ICAO Figure A2-23 and FAA L-880 / FAA L-881.

Features

- Excellent optical system design, red & white transition performance of LED PAPI is superior with straight transition line.
- Self-position design of optical parts, replacement of LED light source without recalibration.
- Front glass is embedded with electric heating wire, which can eliminate condensation without affecting the lighting effect.
- Intelligent electrical control system can automatically turn off the light ion case of abnormal conditions.
- Each light fitting is equipped with a 4-digit LED digital tube to display the elevation angle of the light fitting with high precision.
- The control board is set with "operation mode" and "flight calibration mode" for more convenient use.
- Compact overall structure with small windward area and strong wind resistance.
- The main body of the light fitting is made of corrosion-resistant aluminum alloy with anti-corrosion surface treatment. All fasteners are made of stainless steel, suitable for various harsh environments.
- Equipped with independent level in horizontal and longitudinal direction for convenient installation and maintenance.

Specifications

- Power: 2.8A ~ 6.6A
- 1x100W / 6.6A Isolation transformer
- Average life: minimum 60.000h at maximum brightness and 100.000h in a normal operating conditions.
- Colors: Red and White
- Consumption: 77VA; FP >0,95
- Index Protection: IP65.

PAPI-LED | LED Precision Approach Path Indicator (PAPI) - Airsafe

Order Code

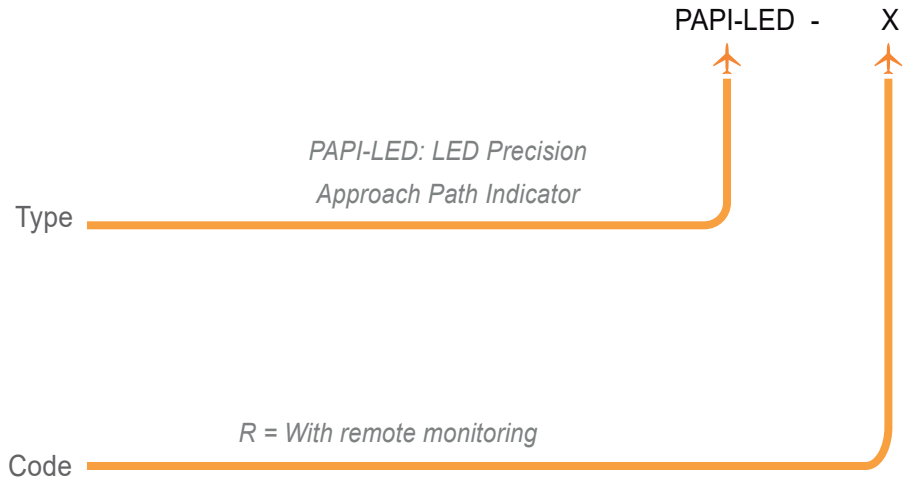

Installation

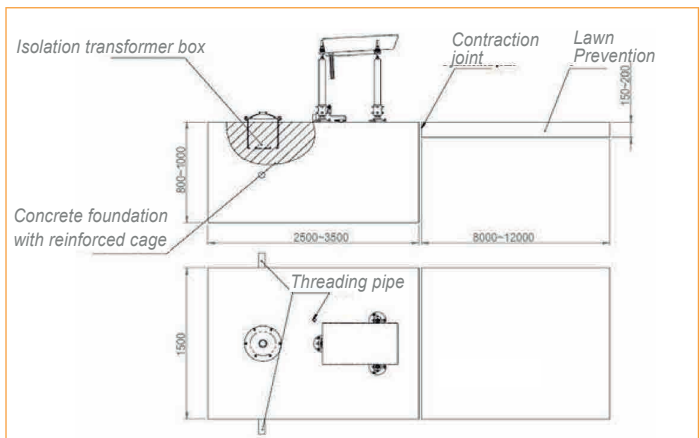
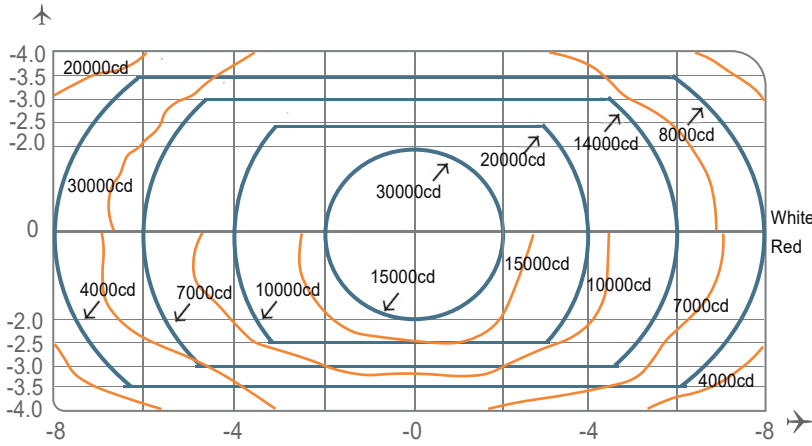

Figure 1

PAPI-LED | LED Precision Approach Path Indicator (PAPI) - Airsafe

Photometry



Light Intensity distribution of PAPI, ICAO figure A2-23, FAA L-880/L-881

Application		Main Beam		Color	Required min. avg. cd.	Actual avg. cd.
		H	V			
PAPI-LED	ICAO Fig A2-23 FAA L-880 / L-881	± 2°	± 2°	White	30.000	81.693
				Red	15.000	15.509
		± 4°	± 2,5°	White	20.000	65.404
				Red	10.000	12.605
		± 6°	± 3°	White	14.000	42.597
				Red	7.000	9.461
		± 8°	± 3,5°	White	8.000	16.560
				Red	4.000	7.314

PAPI-LED | LED Precision Approach Path Indicator (PAPI) - Airsafe



Structure

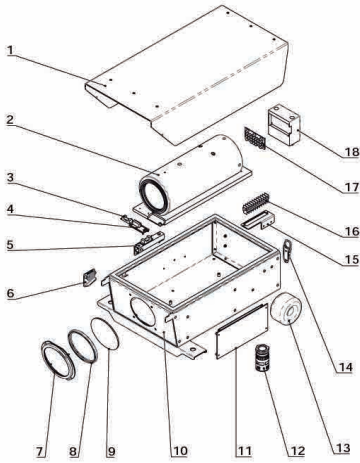

- 1 Upper cover assy
- 2 Optical lens
- 3 Horizontal indicator
- 4 Digital display board
- 5 Longitudinal level module
- 6 Refrigeration module
- 7 Sealing ring
- 8 Glass sealing ring
- 9 Front glass
- 10 Box
- 11 Driver
- 12 Hose connector
- 13 Transformer
- 14 Hasp
- 15 Bracket
- 16 Terminal block
- 17 LED light source assy
- 18 Light source holder

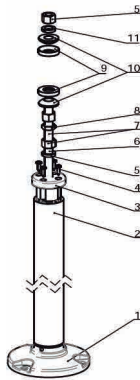

- 1 Flange
- 2 Leg
- 3 Leg end cover
- 4 Self tapping screw
- 5 Spring washer
- 6 Screw stem
- 7 Hexagon nut
- 8 Thin hexagon nut
- 9 Spherical upper washer
- 10 Spherical lower washer
- 11 Wave spring washer

Spare Parts

BOX

N°	Order No.	Description
24	31149	Front glass
18	979247	Light source assy
26	ZJ4-481410C	Horizontal indicator
27	7911L	Digital display board
29	7911D	Driver
31	7912S	Transformer

LEG ASSY

N°	Order No.	Description
1	276A1	Flange
2	46322	Leg

PAPI-LED | LED Precision Approach Path Indicator (PAPI) - Airsafe

Accessories

N°	Order No.	Description
1	ITF-100-066	100W isolation transformer
2	TJB-12	Isolation transformer box

Weight and Dimensions

	1xLED PAPI unit	12xLegs + 12xFlange plates
Packaging size	840x550x270mm ³	840x550x270mm ³
Weight	31,0 kg	28,50 kg

Dimensions

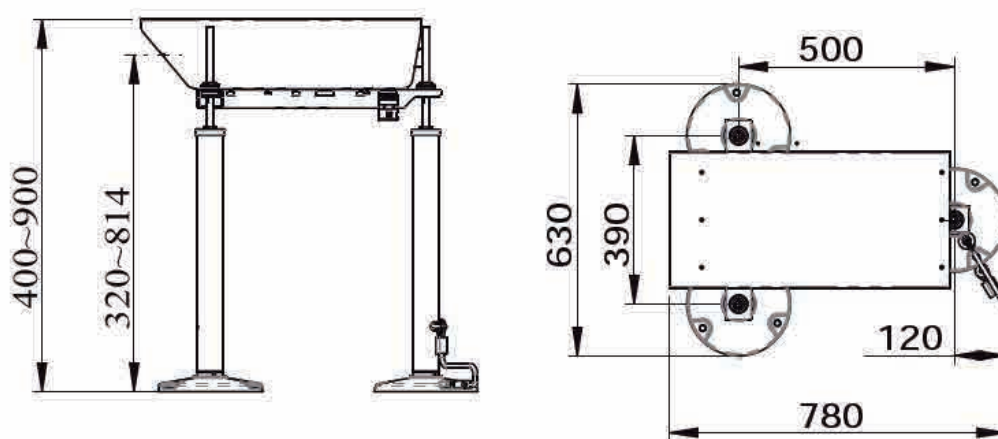

PAPI-LED | LED Precision Approach Path Indicator (PAPI) - Airsafe



Instructions

